

EsGate 3

Safety switching device for sensors with 8,2 kΩ

Translation of the original instructions

General

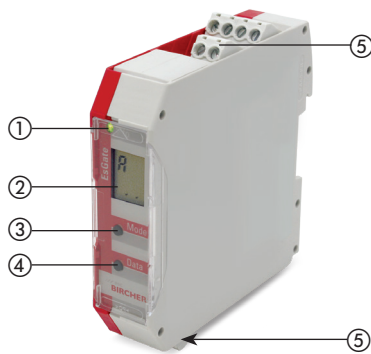

- ① LED
- ② LCD display
- ③ "Mode" button
- ④ "Data" button
- ⑤ Terminals

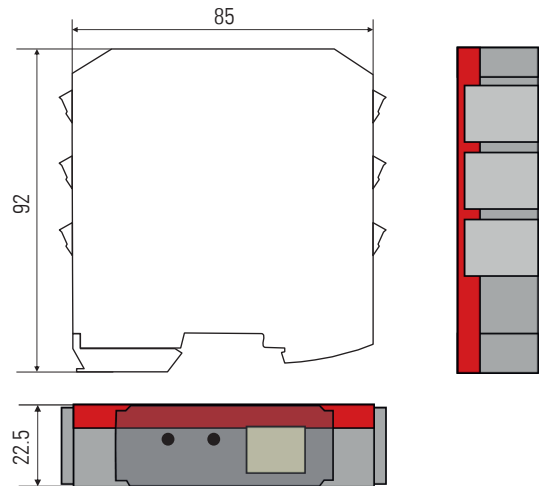

1 Safety Instructions



- Read these operating instructions thoroughly before putting the device into operation and keep them for future reference.
- Do not use this product other than for its specified application.
- Only trained and qualified personnel may install and initialize the device.
- Only authorized factory personnel may perform hardware/software changes or repairs to the product.
- Pay attention to all local relevant electrical safety regulations!
- Failure to follow these safety precautions may cause damage to device or objects, serious personal injury, or death.
- It is the responsibility of the equipment installer to carry out a risk assessment and to install the system, in compliance with applicable local, national and international regulations, safety standards, codes and laws as well as the Machinery Directive 2006/42/EC, should this apply.
- Observe all applicable local, national, and international door safety standards, codes, and laws.
- Always consider the safety functions of your applications as a whole, never just in relation to one individual section of the system.
- The installer is responsible for testing the system to ensure it meets all applicable safety standards.
- During the operation of electrical components
 - e. g. in the case of a short circuit hot and ionised gases can be emitted; protection covers must not be removed!

- The device should only be operated from a safety extra low voltage (SELV) system with safe electrical separation according to EN 61558.
- The wiring must be protected against mechanical damage.

Prior to starting installation or mounting, take the following safety precautions:

- Check the voltage data on the label of the switching device.
- Ensure that the device/installations cannot be switched on!
- Ensure that the power supply is disconnected!
- Protect the device with a housing against contamination or harsh environments!
- Cover any neighbouring live parts or remove them!
- Disconnect device from mains in the event of a fault.
- Avoid touching any electronic components.
- Limited protection against accidental contact!

2 Intended use

The EsGate 3 switching devices are used to monitor the manufacturer's pressure-sensitive protective devices (for safety edges according to EN ISO 13856-2) on industrial gates/doors. They comply with the requirements of the standard EN ISO 13849-1 for protective devices up to PL e, Cat. 3. If the safety device is not requested operationally at least once a month, it must be checked automatically or manually by the operator at least once a month. The device can be installed in a simple, industrial or even controlled electromagnetic environment.

Common Application

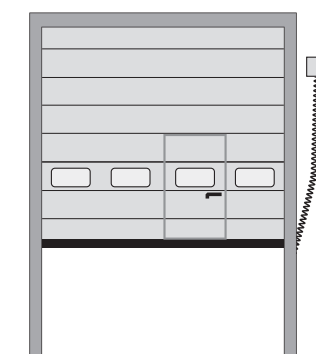

3 Function

Connected sensors with a terminating resistor of 8.2 kΩ are monitored for a change in current.

In the idle mode

- all safety outputs are conductive
- the LED lights up green
- both dots on the display flash



When one or more sensors are **actuated**

- the total resistance of the sensor system drops towards zero Ω
- the defined switching threshold is not reached anymore
- the corresponding Safety output opens
- the LED lights up orange, P appears on the display



In the event of a **fault** in the sensor circuit (for example cable breakage)

- the total resistance of the sensor system increases
- the defined switching threshold is exceeded
- **both** Safety outputs open
- the LED lights up red, E appears on the display



Block diagram

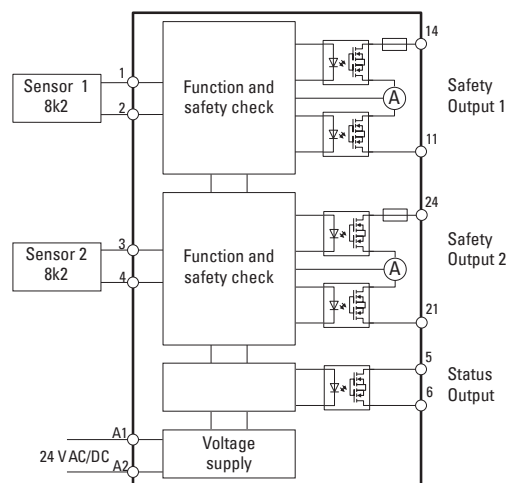

4 Configuration and set-up

4.1 Terminals

Wiring the device

- A1 / A2: ▲ Supply voltage (24 V AC/DC)
- 1 / 2: Sensor 1
- 3 / 4: Sensor 2
- 11 / 14: ▲ Safety output 1
- 21 / 24: ▲ Safety output 2
- 5 / 6: Status output

- Ⓛ No function test possible without connected outputs (Display E 007 or E 008)
- ▲ Wiring mandatory

4.2 Switch on supply voltage

If necessary, configure the device

4.3 Function test

Function test

- Press sensor 1, check LED (orange), display (P Ⓛ, 1). Check if output 1 is open.
- Release sensor
- If present, press sensor 2, check LED, display (P Ⓜ, 2). Check if output 2 is open.
- Release sensor

After successful testing, the system is ready for operation.
Display: A and two flashing dots



Outputs

Contacts	Unpowered	Sensor 1 idle	Sensor 1 actuated	Sensor 2 idle	Sensor 2 actuated	Sensor 1 + 2 idle	Fault
Safety output 1	OPEN	closed	OPEN			closed	OPEN
Safety output 2	OPEN			closed	OPEN	closed	OPEN
Status output	OPEN		OPEN		OPEN	closed	OPEN

4.4 Diagnostic menu (read only)

⏏ Data ⏏ Mode ⏏ Back to top ⏏ Back to start

	⏏ E	⏏ r	⏏ S	⏏ S	⏏ S	⏏ C	⏏ h	⏏ C	⏏ ↵
	Errors flash	Resistors	Output 1	Output 2	both outputs	Configu-ration	Fall-delay time	Configu-ration	
Error 5 latest	1 value	1 or E	1 or E	11 or E	C 001	h 002	con		
Error 4	2 value	0 or E	0 or E	00 or E			con (flashing)		
Error 3									
Error 2									
Error 1									
End									

Access Configuration (see chapter 4.5)

Enter Diagnostic menu:

Press "Mode" and "Data" buttons simultaneously for 2 seconds → Status LED flashes orange
 To see the next parameter, press "Mode", Data query (Mode E and r): press "Data"

Exit Diagnostic menu:

⏏ Press "Mode" button for 2 seconds

- E last 5 error messages (displayed by pressing "Data")
- r current resistances of the sensors (displayed in kΩ: 1, 2, 4, 6, 8, 10, 12 or 14)
- S ① shows the state of output 1:
output activated, 1 = current flow ≙ okay, E = no current flow ≙ error (press "Data") output deactivated, 0 = no current flow ≙ okay, E = current flow ≙ error
- S ② shows the state of output 2:
output activated, 1 = current flow ≙ okay, E = no current flow ≙ error (press "Data") output deactivated, 0 = no current flow ≙ okay, E = current flow ≙ error
- S ① ② shows the state of both outputs:
outputs activated, 1 = current flow ≙ okay, E = no current flow ≙ error (press "Data") outputs deactivated, 0 = no current flow ≙ okay, E = current flow ≙ error
- C shows the current configuration (active inputs):
001 = both inputs 1 and 2, 002 = only input 1, 003 only input 2
- h The holding time (extension of the output signal):
001 = none, 002 = 100 ms, 003 = 200 ms, 004 = 500 ms, 005 = 1000 ms
- C configuration: entering into the configuration mode by pressing "data" → chap. 4.5

4.5 Configuration mode (edit mode)

To enter Configuration menu (see also chapter 4.4):

- Enter diagnostic menu: Press "Mode" and "Data" buttons simultaneously for 2 seconds → Status LED flashes orange.
- Press "Mode" repeatedly until "C" and "con" are displayed.
- Press "Data" button, "con" starts flashing.
- Press "Mode" and "Data" buttons simultaneously until "con" stops flashing.
- Release "Mode" and "Data", "C" starts flashing, both safety outputs open.

	⏏ C	⏏ h	⏏ h
	Configu-ration	Holding time	End
001*	Sensor 1 + 2	none	
002	Sensor 1	100 ms	
003*	Sensor 2	200 ms	
004		500 ms	
005		1 s	

Exit Configuration menu

* Factory setting

On initial commissioning, the device must be adapted (configured) to the application.

Configuration

- Press the "Mode" button to select the requested parameter.
- Press the "Data" button to set the value.

Exit Configuration menu:

Press "Mode" until "h End", then press "Data".

Adjustable parameters:

- C active inputs: 001 = both inputs 1 and 2, 002 = only input 1, 003 only input 2
- h The holding time (extension of the output signal):
001 = none, 002 = 100 ms, 003 = 200 ms, 004 = 500 ms, 005 = 1000 ms

4.6 Service mode

Data
 Mode
 Back to top
 Back to start

10 sec

H	S	t	U	o	E	E
Hardware version	Software version	Type	Supply voltage	Internal temperature	Errors flash	Errors flash
005	5.12	3	value	value	Error 5 latest	rES
					Error 4	--- 2 sec
					Error 3	
					Error 2	
					Error 1	
					End	

Enter Service mode: Press "Data" for 10 seconds
 → Green status LED flashes
 To show the next parameter, press "Mode"
 Data query in each mode: press "Data" button
Exit Service mode: Press "Mode" button for 2 seconds

In the service mode, further information can be displayed:

- H Hardware Version
- S Software Version
- t Type (Cat. acc. to EN ISO 13849-1)
- U Internal supply voltage
- o Current chip temperature
- E The last five error messages (displayed by pressing "Data")
- E rES: press and hold "Data" button until --- is displayed to reset the error messages

4.7 Error displays

	If an error is detected both safety outputs are deactivated and symbols ① & ② and an error code are displayed. The status LED lights up red.						
Display	E001	E002	E006	E007	E008	E101	E102
Error	Sensor 1 wiring defective	Sensor 2 wiring defective	Configuration mode incorrectly set	① Outputs not OK	②	Undervoltage	Overvoltage
Remedy	Check sensor 1	Check sensor 2	Check configuration	Check output wiring		Check supply	

Should other fault messages appear, please contact your supplier.

5 Technical Data

Operating voltage	24 V DC ±15 % 24 V AC ±15 %, 50/60 Hz
Power consumption	max. 3 W
Inputs sensors	for sensors with 8,2 kΩ termination
Safety outputs	Solid state relays, 24 V DC, min. 0.5 mA, max. 50 mA internally protected by a fuse R _{DS(on)} ca. 60 Ω
Status output	Solid state relays, 24 V AC/DC, max. 50 mA, R _{DS(on)} ca. 30 Ω
Reaction time (at activation)	< 20 ms

Start-up time	< 500 ms
Housing	Polyamide grey / red
Dimensions	22,5 x 94 x 88 mm (W x H x D)
Mounting	Direct DIN-rail mounting
Terminals	Pluggable screw terminals
Protection class	IP20 (EN 60529)
Operating temperature	-20°C to +60°C
Storage temperature	-40°C to +70°C
Humidity	Max. 95% relative, non-condensing

6 EU Declaration of Conformity

See attachment

7 WEEE



Devices with this symbol must be treated separately during disposal. This must be done in accordance with the laws of the respective countries for environmentally sound disposal, processing and recycling of electrical and electronic equipment.

8 Contact

BBC Bircher Smart Access, BBC Bircher AG, Wiesengasse 20, CH-8222 Beringen, www.bircher.com
 Designed in Switzerland / Made in Bulgaria