



NEW: AC version with WIDE RANGE voltage connection

TUBELED_70

Temperature-resistant, proven, versatile

The TUBELED_70 is the ultimate LED machine light. A light with the latest LED technology that fits exactly into the brackets of conventional tubular luminaires of older machine tools and enables a quick 1:1 exchange for a previous $\varnothing 70$ mm light. Two optics and two connection variants are available for initial equipment or for conversion. Thanks to good thermal management, the TUBELED_70 is also suitable for use in higher temperature ranges.

The Technology

- Heat dissipation via the extruded aluminium profile
- Safety glass, crack-proof, 4 mm thick
- Oil-resistant seals (FKM seal Viton®)
- Installed in the "machine space" – chip bombardment-proof, vibration and shock resistant – 100% CNC suitable

Your benefits

- Concentrated light (60° variant) or wide spread light (100° variant) – individual optics possible on request
- Flicker-free without UV and IR components
- Quick and easy upgrading or retrofitting

Areas of application

- Machine tools, CNC machines, outdoor applications

Designs/installation

- 4 lengths 300 mm, 560 mm, 1100 mm, 1580 mm
- Mounting via separately available luminaire holders

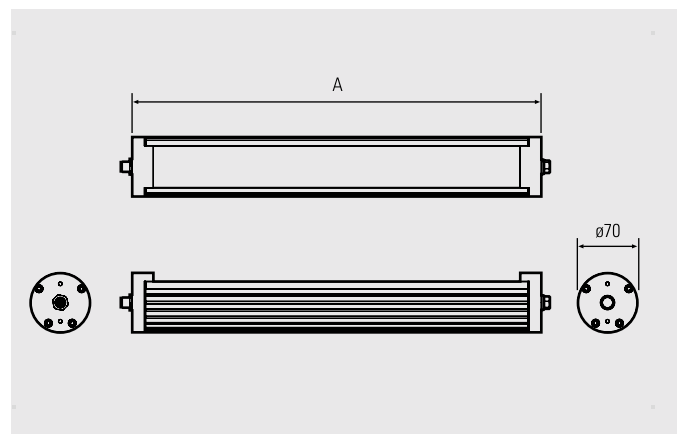



TUBELED_70, 24V DC, 5200-5700K	Product no.	Length (A)	Optics	E _{max} *	Lamp luminous flux	Output	Connection
TUBELED_70 DC, 100° optics	110310-01	300 mm	100°	522 lx	1848 lm	~15 W	24V DC
TUBELED_70 DC, 60° optics	110314-01	300 mm	60°	1455 lx	1526 lm	~15 W	24V DC
TUBELED_70 DC, 100° optics	110410-02	560 mm	100°	1005 lx	3032 lm	~27 W	24V DC
TUBELED_70 DC, 60° optics	110414-02	560 mm	60°	2720 lx	3052 lm	~27 W	24V DC
TUBELED_70 DC, 100° optics	110510-02	1100 mm	100°	1695 lx	6064 lm	~54 W	24V DC
TUBELED_70 DC, 60° optics	110514-02	1100 mm	60°	4173 lx	6104 lm	~54 W	24V DC
TUBELED_70 DC, 100° optics	110710-02	1580 mm	100°	2047 lx	9096 lm	~80 W	24V DC
TUBELED_70 DC, 60° optics	110714-02	1580 mm	60°	4762 lx	9156 lm	~80 W	24V DC
TUBELED_70, 90-305V AC, 5200-5700K	Product no.	Length (A)	Optics	E _{max} *	Lamp luminous flux	Output	Connection
TUBELED_70 AC, 100° optics	110310-11	300 mm	100°	522 lx	1848 lm	~17 W	90-305V AC
TUBELED_70 AC, 60° optics	110314-11	300 mm	60°	1455 lx	1526 lm	~16 W	90-305V AC
TUBELED_70 AC, 100° optics	110410-12	560 mm	100°	1005 lx	3032 lm	~28 W	90-305V AC
TUBELED_70 AC, 60° optics	110414-12	560 mm	60°	2720 lx	3052 lm	~31 W	90-305V AC
TUBELED_70 AC, 100° optics	110510-12	1100 mm	100°	1695 lx	6064 lm	~52 W	90-305V AC
TUBELED_70 AC, 60° optics	110514-12	1100 mm	60°	4173 lx	6104 lm	~60 W	90-305V AC
TUBELED_70 AC, 100° optics	110710-12	1580 mm	100°	2047 lx	9096 lm	~74 W	90-305V AC
TUBELED_70 AC, 60° optics	110714-12	1580 mm	60°	4762 lx	9156 lm	~85 W	90-305V AC

PSU and connection materials, see Accessories.

* maximum lighting intensities, measurement area 100 cm x 100 cm at 100 cm distance

Accessories	Product no.
TUBELED_70 Mounting bracket, V2A, 1 pair	210200-01
TUBELED_70 Luminaire holder, aluminium, 1 pair	210200-02